

LED CE

INMP51R

Industrial Rechargeable LED Handlamp

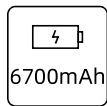

Lithium Battery



Waterproof and Dustproof



Anti-corrosion

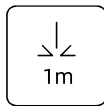

Impact Resistant



Description

- Widely used for inspection, emergency repair and construction emergency lighting etc. in industrial area and professional industry.
- The body is made of high performance nylon. It features as lightweight, anti-aging, anti-corrosion, impact-resistant and easy to carry.
- Professional optical lens design, soft illumination, uniform spot, in line with GB 30734 fire protection standard.

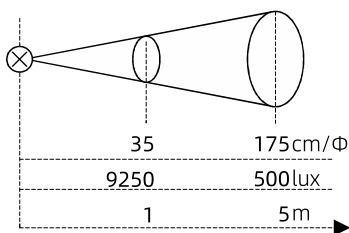

Parameters

Certification:	CE
Working ambient temp.:	-40°C≤Ta≤+55°C
Ingress protection:	IP66/67
Corrosion-proof grade:	WF2
CCT:	6500K
Luminous flux:	≥610lm (strong mode), ≥310lm (work mode), ≥310lm (SOS mode)
Run time:	≥11h (strong mode), ≥20h (work mode)
Beam distance:	≥193m (strong mode), ≥134m (work mode)
Battery type:	18650 lithium battery (IEC 61233, IEC 61960)
Battery capacity:	7.2V, 6700mAh
Charging way:	match 1000/01-B51 charging base
Charging time:	≤12h
Recharging cycles:	500 cycles
Lifespan:	50,000h (without battery)
Light source color:	Red, Yellow, Green, White

Note: The luminous flux and continuous discharge time are the values measured under the environment of -20°C≤Ta≤+55°C.

Features



90° rotational head



Comes with 4 color light source, switch by knob. ○ ● ● ● ●



Charging indicator



The head adopts advanced insert over-molding of glass with high performance nylon material.



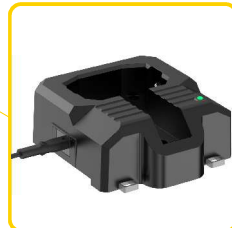

Large button, designed for industrial use, is made of durable, chemical-resistant nylon. 4 grids power display.



Matched charging base, safer and more reliable.

Order specifications

Illustration	Description	Weight (g)	Order No.
	Industrial Rechargeable LED Handlamp	960	INMP51R
	Industrial Rechargeable LED Handlamp + Charging base + Power cord	1367	INMP51R+B51-□

GB
 EN
 BS
 ANSI
 AS
 JIS

Code of plug

Note: Users can choose type B integrated charging track rail and integrated charging stand. Please see pages 03-05 for details.

Charging system

- INMP51R is equipped with a dedicated charging base to ensure safe use. The charging base has a charging indicator light, red means charging, green means fully charged.
- The charging base has 3 charging ports - AC 100-250V/3A, DC 5.0V/3A and a matched integrated charging port at the bottom. Safe, simple and convenient.
- This product is suitable for type B integrated charging track rail.

DC 5.0V/3A

AC 100-250V,
50/60Hz

Individual Charging

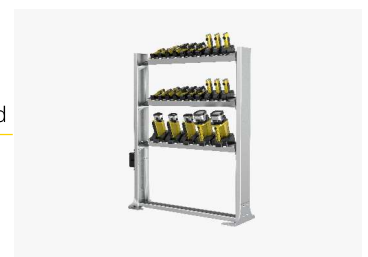

Type B Integrated
Charging Track Rail

Integrated Charging Stand

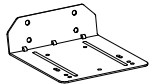
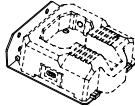
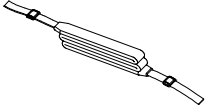
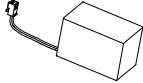

Note: For technical parameters of integrated charging track rail and integrated charging stand, please refer to pages 03-05.

Spare parts

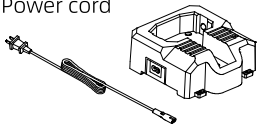
Illustration	Description	Weight (g)	Order No.
	 304 stainless steel	435	1000/11-03-01
	/	30	1000/11-02-01
	7.2V, 6700mAh	230	1000/05-R51
	Input voltage/current: DC 5.0V/3000mA	94	1000/12-01
	Input voltage/current: AC 100-250V/3000mA Input voltage/current: DC 5.0V/3000mA	394	1000/01-B51-□



Code of plug

Outline dimension (unit: mm)

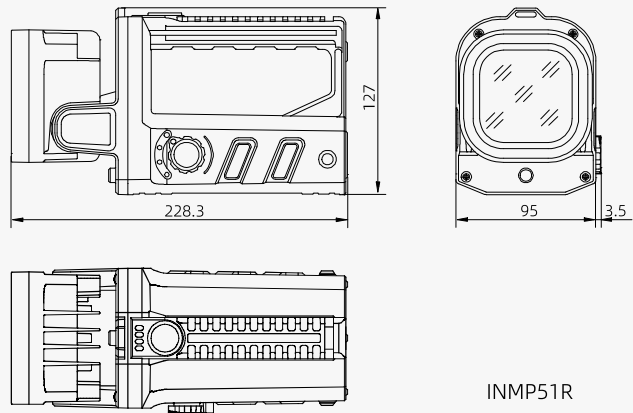

INMP51R

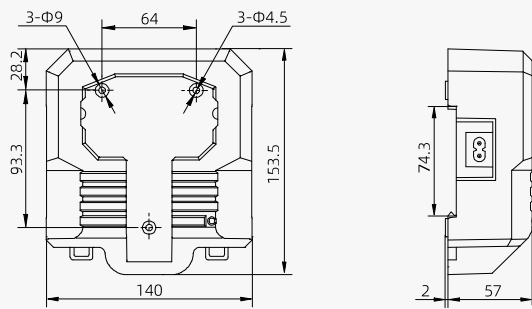

1000/01-B51

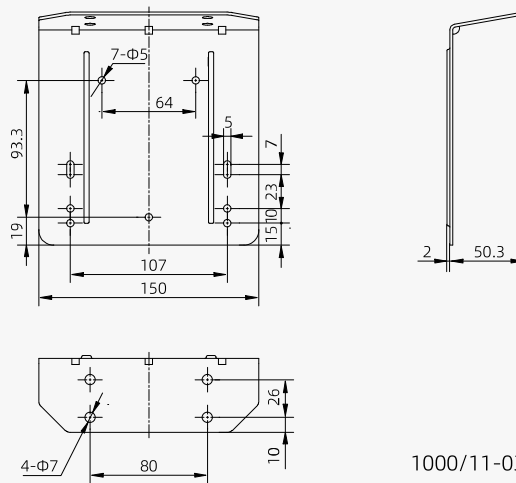

1000/11-03-01